

FOR THE
ORDER
OF
THE
ROYAL

THE





ROMAN & WILLIAMS 10
HOMES & DETAILS 18
KITCHEN 24
BATHS 32
SERVICES & AMENITIES 40
NEIGHBORHOOD 46
TEAM 50

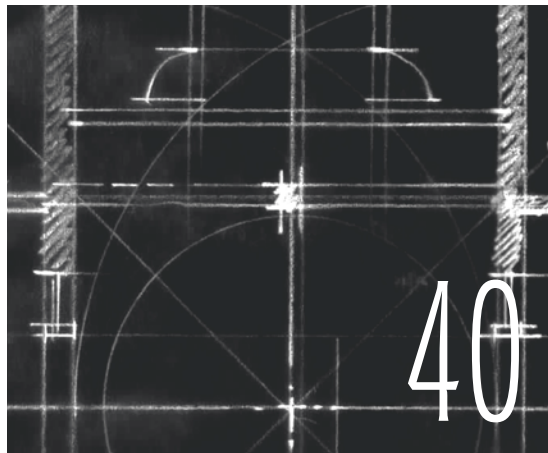
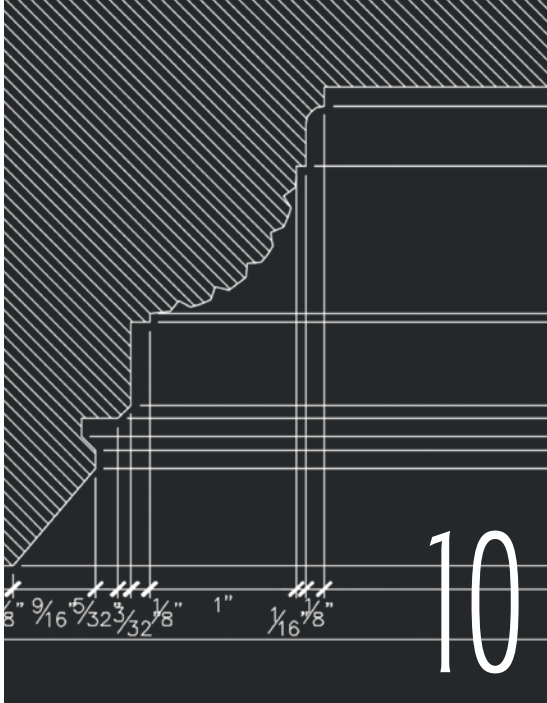

FITZROY
THE

"WE ARE INTERESTED IN SPACES AND OBJECTS THAT PEOPLE CAN TRULY USE AND THINGS THAT GENUINELY LAST. WE ARE DEVOTED TO REBELLING AGAINST DISPOSABILITY AND THE COMMON STEREOTYPES OF WHAT IT MEANS TO BE 'MODERN' TODAY."

Roman and Williams is, first and foremost, focused on people and their experiences of a space. Firm principals Robin Standefer and Stephen Alesch founded Roman and Williams Buildings and Interiors, named after their grandfathers, in New York City in 2002.

Roman and Williams believes that the story of a space is just as important as the design and the objects that go into it — it all plays into the experience. As a firm, they are never focused on a definitive style from any era, as seen in their work on projects as diverse as Ace Hotel New York, The Boom Boom Room at the Standard Highline, the Chicago Athletic Association Hotel and custom homes. They love to strip things down to their essence — instead of design, striving for integrity and character. They consistently find the tension between spontaneity and vigor, refinement and rebellion, and past and future. The studio places an emphasis on sturdy, well-made objects, custom designing many of the furniture fixtures found in their work. Known for contradictions and the use of layers and eclecticism, Roman and Williams takes a traditional foundation and then rebels against it with lively irreverence.

The firm has received numerous accolades including a Palladio Award for their work on 211 Elizabeth Street, and the prestigious 2014 National Design Award for excellence in Interior Design.

RS It's not easy to translate architecture and design into words.

SA The design language we are exploring involves narratives. We are exploring new areas, focusing on actual experience. This building is one of those narratives.

RS We felt a connection to the contrasts of the first quarter of the 20th Century in New York City. It was an ambitious and complicated period. We're intrigued by the era and its level of craftsmanship and innovation. We strive to push a historical narrative forward and infuse it with new energy, and that means that we have to be very thoughtful about what specific forms and materials we use and how we use them. We chose terracotta and copper because there's a nobility to them that reflects confidence and hope and its very relevant today.

SA Robin has had a piece of green terracotta in the office for years. It's so beautiful. It asked us to become a building.

RS I have always been moved by this particular shade of dark green — it was used in the green terracotta buildings from the same optimistic, expansive era as the McGraw-Hill Building in New York and the Eastern Columbia Building in Los Angeles and this was our chance to use it, to employ this exceptional material - terracotta ages well. It is a living finish that has longevity and evolves and changes with time. It represents many of the values that we embrace.





WELL
DETAILED,
TRIED
&
TRUE



• HOMES & DETAILS •

- All full or half-floor homes
- North and South exposures in every home
 - Ceiling heights of 11'
- Oversized custom wood casement double-pane windows
 - Private elevator entrance and service entrance in each home
 - Oak doors of 8'
 - Oak floors in a chevron pattern
 - Multi-zoned central air conditioning system
 - Hydronic radiant-heated flooring throughout
 - Fine custom millwork throughout
 - Customizable Savant home automation system
 - Miele washers and dryers
 - Nanz door hardware
 - Custom light fixtures by Roman and Williams
 - Fireplaces in select homes
 - Private landscaped outdoor space with summer kitchen in select homes

• BUILDING •

- Green terracotta façade manufactured in Europe by 112-year-old family-owned business
- Custom copper-clad oak windows manufactured by Vermont-based J.S. Benson using a combination of old-world craftsmanship and state-of-the-art practices
 - Lighting designed by L'Observatoire International
- Landscape designed by Evan C. Lai Landscape Designs

RS The Fitzroy really expresses an essential principle of ours and marks the trajectory of our development: we want to create very durable, well-built, “tried and true” buildings that also unabashedly embrace beauty. It may be a bit unfashionable to talk about buildings being beautiful — but we fully believe in that value.

SA In the last 75 years, architects and designers have often designed buildings that try to look as if they can float or fly. As if they wanted to be elsewhere. We've been fascinated with the opportunity to do a building that is the opposite, something that is firmly planted, something that will be content to be where it is for a long time. We are looking for a structure with steadfast qualities, grounded, leaden, solid, and attributed with gravitas.

RS A building to us is inherently something that should last, that has permanence. It's not ephemeral — when it is of a very high quality it has a different resonance. I wouldn't say all new architecture at this moment on this planet follows that sort of credo but we certainly do.





BRING
BEAUTY
BACK

• KITCHEN •

THE FITZROY PROUDLY FEATURES HANDCRAFTED KITCHENS CONSTRUCTED IN TRUE FINE FURNITURE FORM IN THE SMALLBONE OF DEVIZES WILTSHIRE, UK WORKSHOP. KITCHENS ALSO INCLUDE THE LACANCHE VOUGEOT RANGE, COMBINING HIGH-PERFORMANCE AND A TIMELESS AESTHETIC FROM BERGUNDY, FRANCE.

- Custom Smallbone of Devizes kitchens by Roman and Williams
 - Black enameled Lacanche range with blackened brass dials
 - Fully integrated Miele dishwasher, steam oven, and warming drawer
- Fully integrated Sub-Zero refrigerator and freezer
 - Undercounter Sub-Zero wine refrigerator
 - Waterworks R.W. Atlas by Roman and Williams hardware in carbon and copper finishes throughout
 - Decorative pendants in copper finish by Roman and Williams
 - Fiore de Pesco marble countertop

SA We like to place our mindset into the last stages of the Pre-War period — the period just before detachment, disconnection and abstraction took hold. But rather than remaining fixed in that time we turn forward and move into the future exploring where we might have gone if architectural traditions continued to push ornament, articulation, detail and the pursuit of beauty. Our work is now about reconnection and reattachment — to our culture, our families, our history, and beauty. It is time.

RS Reconnection is very meaningful to our practice — we want to help people reconnect to the un-ironic, uninhibited love of beauty. We're in a time when a lot of buildings are highly conceptual and beauty is just not part of the dialogue. If anything, beauty is perceived as a negative — as superficial or shallow. But it's essential. It's what drives us to get up in the morning.

If you begin to think of this principle not as an abstraction but as shaping where people are going to eat and sleep and live — making a home — then it makes sense to bring beauty back because it becomes physical, tangible, visceral.

SA I really know and believe that it's my time on earth — my time to create good homes, to live in and build good architecture ... these are not things of another era that I cannot have or do.



01 • WATERWORKS R.W. ATLAS COPPER PULLS

02 • LACANCHE VOUGEOT STOVE DETAILS

03 • R.W. ATLAS WALL MOUNTED POT FILLER IN CARBON FINISH

04 • FIORE DE PESCO STONE AND COPPER BACKSPLASH

05 • R.W. ATLAS KITCHEN FAUCET AND SPRAY IN CARBON FINISH



01

02

02

04

03

05

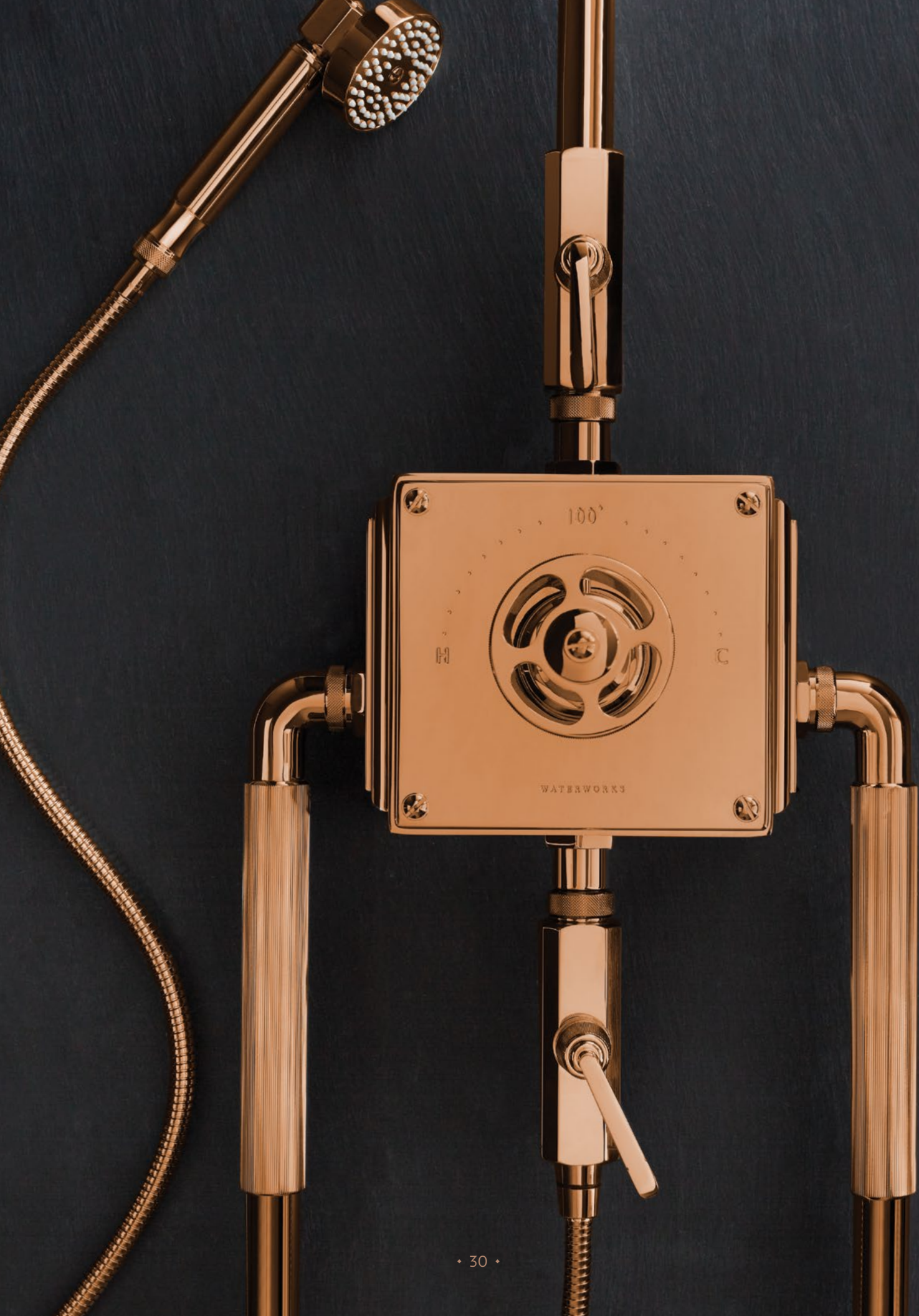

LIVING
FINISHES:
COPPER
CARBON
BRASS

• MASTER BATHROOM •

- William Holland Cuprosa Bateau copper soaking tub
 - Steam shower
 - Hydronic radiant-heated flooring
- Waterworks R.W. Atlas copper fixtures including handheld shower with thermostatic controls
 - Custom glass rod sconces and mirror by Roman and Williams
 - Paonazzo slab marble walls
 - Nero Marquina slab marble floors
 - Custom integrated millwork storage
 - Custom blackened brass vanity with inked wood cabinet doors

• SECONDARY BATHROOM •

- R.W. Atlas fixtures including handheld shower with thermostatic controls in a carbon finish
- Custom sconces and mirror by Roman and Williams
 - Calacatta Crema marble walls and floors

• POWDER ROOM •

- R.W. Atlas fixtures in a carbon finish
- Custom pendant and mirror by Roman and Williams
- Calacatta Macchia Vecchia marble walls and floors

RS Stephen and I don't do many condominiums but when we do we choose partners very carefully because we want to collaborate with people who believe in creating something that will last and who will invest in doing that properly, because these days it can be a costly endeavor. Hence why this is a rare building; it takes great commitment from all parties to achieve beauty and substance to that level of detail — and the details are typically the first thing to be sacrificed in modern buildings, but to us those are the things about buildings in New York that are essential. Generally new construction is extremely disappointing.

SA Beauty resonates in the soul. In nature and the built world it has this ability to become an aesthetic force that is beyond language. We're grateful to have found people who share an interest and understanding of the value of making beautiful things that last.



01 • WATERWORKS R.W. ATLAS COPPER FIXTURES AND HAND HELD SHOWER

02 • R.W. ATLAS ROUND KNOBS

03 • R.W. ATLAS THERMOSTATIC CONTROL VALVE IN CARBON FINISH

04 • CUSTOM MIRROR BY ROMAN AND WILLIAMS

05 • PAONAZZO SLAB MARBLE WALLS AND NERO MARQUINA MARBLE FLOORS

06 • R.W. ATLAS FAUCET WITH METAL WHEELS IN CARBON FINISH



01

01

04

05

02

03

06



• SERVICES & AMENITIES •

THE EXCLUSIVITY, PRIVACY AND SECURITY
OF HAVING ONLY 13 NEIGHBORS

- 24-hour attended lobby
- La Palestra designed fitness center with:
 - dynamic movement studio,
 - cardio studio, yoga & pilates room,
 - treatment room, and dry sauna
- Wine cellar with secure wine locker for each home
- Climate-controlled, fully customizable storage room for each home, up to 165 sq. ft.
- Landscaped rooftop lounge with summer kitchen
 - Children's art studio
 - Auxiliary laundry room with large washers and vented dryers
 - Bicycle storage

RS I don't love the description 'timeless' or 'classic.' They mean much less to me than some of the eternal principles that have ensured that certain objects or monuments endure. It means more to me that something is sturdy, substantial and well-detailed, because the truth is we can't know the future — but we can make sure we head into it armed with as much strength as we can carry forward. It's the best ethos we have found, that's why we mine the past so repeatedly and consistently — because the past moves us so much. But it's not about nostalgia for a certain period, if anything it's more about the elaborate detail that was created and expected in those eras — it's easier to develop emotions and a sense of attachment for something that has been lovingly, excellently crafted.

SA We are not alone in loving these things. People are hungry for a substantial experience, to touch something that has resonance, to feel a sense of solidity. These are ancient instincts and they are too often denied in the synthetic era.

RS That is an essential thread through our work. If anything, all of our work reflects a certain innate philosophy about things made well that humans can sense on an almost subconscious level.

• THE FITZROY AMENITIES •





• WEST CHELSEA •

A CONNECTING NODE FOR MANHATTAN:
ART, HISTORY, CULTURE, NATURE AND CITY

West Chelsea is one of Manhattan's most vibrant neighborhoods, home to the High Line, Whitney Museum of Art, and world-renown art galleries. Once the sprawling estate of Thomas Clarke, a retired British Major and grandfather to Clement C. Moore, Chelsea's original apple orchards and farmlands passed from one generation to another, all the while being developed into a blend of Georgian residential buildings and bustling industries dotting the Hudson River.

The origin of the Fitzroy stems from a British Lieutenant General named Charles Fitzroy who resided in the Greenwich Village area in the eighteenth century. His military success brought forth naming a highway in his honor. Before the Manhattan grid, the Fitzroy Road ran through current day Chelsea, from West 14th Street through present Eighth Avenue, to 40th Street and Ninth Avenue.

Today, the area maintains hints of its past, with tree-lined streets interspersed with architecture reflecting the neighborhood's unique Neo-Gothic, Greek Revival and Art Deco history. West Chelsea is now synonymous with art, fashion, culture, restaurants, and renowned galleries alongside the Hudson River. The celebrated, elevated High Line park, built on a historic freight line, runs from the adjacent Meatpacking District to the highly anticipated Hudson Yards project.

- RS There is something about the idea of being in a metropolis, this furnace of a city where there is a mass of architecture from various periods and everything crashes into each other and yet THAT turmoil still has to be woven into a fabric. That unrelenting, extraordinary fabric is something we want to be a part of.
- SA It is such a gift to have the Hudson River and the High Line as neighbors for the building; it's a perfect setting to introduce the green palette of the terracotta and the glazing.
- RS The reflectivity of this vitreous glaze is extraordinary. It almost feels like the river has burnished the surface of the building. Green is also inspiring from the point of view of the technique and the elements it takes to make it. What you have to add to the clay to create that ceramic glaze is various combinations of minerals, sands and metals. We love the alchemy of that — firing something in a kiln is a bit unpredictable and that creates a variation that feels good, it means it's okay to be a bit uneven, a bit mottled.
- SA We are also avid gardeners, living primarily outside during our time away from the studio. Sitting in our grass and looking at our plants and trees, we've noticed that everything is variations of green on top of a layer of blacks. I've learned to use this simple layering in my landscape paintings. One cannot simply smear green paint all over the place, it must be set upon a base of dark under-painting. When you get it right, you feel it in your heart.
- RS The Fitzroy's palette and materials are about elevating and articulating that sense of contrast, the nourishing, ripe green of the park and the river versus the grit of the city. Stephen talks about the building's connection to the Hudson and the many green shades of the High Line because the placement of the building heightens that contrast that is always part of the tension of New York City. There's a modesty to that, but also an elegance — and a message.

• NEIGHBORHOOD •

RESTAURANTS

01. CATCH 21 NINTH AVE
02. COLICCHIO & SONS 85 10TH AVE
03. COOKSHOP 156 10TH AVE
04. DEATH AVE, ESTIATORIO & ZYTHOPOIEIO
315 10TH AVE
05. DEL POSTO 85 10TH AVE
06. THE MONARCH ROOM 408 W 15TH ST
07. THE RED CAT 227 10TH AVE
08. SCARPETTA 355 W 14TH STREET
09. SULLIVAN STREET BAKERY 236 9TH AVE
10. VALBELLA 421 W 13TH ST

RETAIL

11. 192 BOOKS 192 10TH AVENUE E
12. APPLE 401 W 14TH ST
13. COMME DES GARÇONS 520 W 22ND ST
14. DIANE VON FÜRSTENBERG
874 WASHINGTON ST
15. JEFFREY 449 W 14TH ST
16. LOST ART 509 W 27TH ST
17. RAG & BONE 425 W 13TH ST
18. THEORY 40 GANSEVOORT ST
19. VITRA 29 NINTH AVE

CULTURE & LIFESTYLE

20. ATLANTIC THEATER COMPANY
336 W 20TH ST
21. CHELSEA MARKET 75 NINTH AVE
22. CHELSEA PIERS 62 CHELSEA PIERS
23. EQUINOX 100 10TH AVE
24. EXHALE SPA 18 NINTH AVE
25. HIGHLINE BALLROOM 431 W 16TH ST
26. THE HIGH LINE

ART & GALLERIES

27. BARBARA GLADSTONE 515 W 24TH ST
28. CRISTIN TIERNEY 540 W 28TH ST
29. DAVID NOLAN NEW YORK 527 W 29TH ST
30. DAVID ZWIRNER GALLERY 525 W 19TH ST
31. DIA FOUNDATION 535 W 22ND ST
32. GAGOSIAN GALLERY 555 W 24TH ST
33. HELLER GALLERY 303 10TH AVE
34. JONATHAN LEVINE GALLERY 529 W 20TH ST
35. MIXED GREENS 531 W 26TH ST
36. PACE GALLERY 508 W 25TH ST
37. PAUL KASMIN GALLERY 293 10TH AVE

HOTELS

38. SOHO HOUSE 29-35 NINTH AVE
39. THE HIGH LINE HOTEL 180 10TH AVE
40. THE STANDARD HIGH LINE
848 WASHINGTON ST

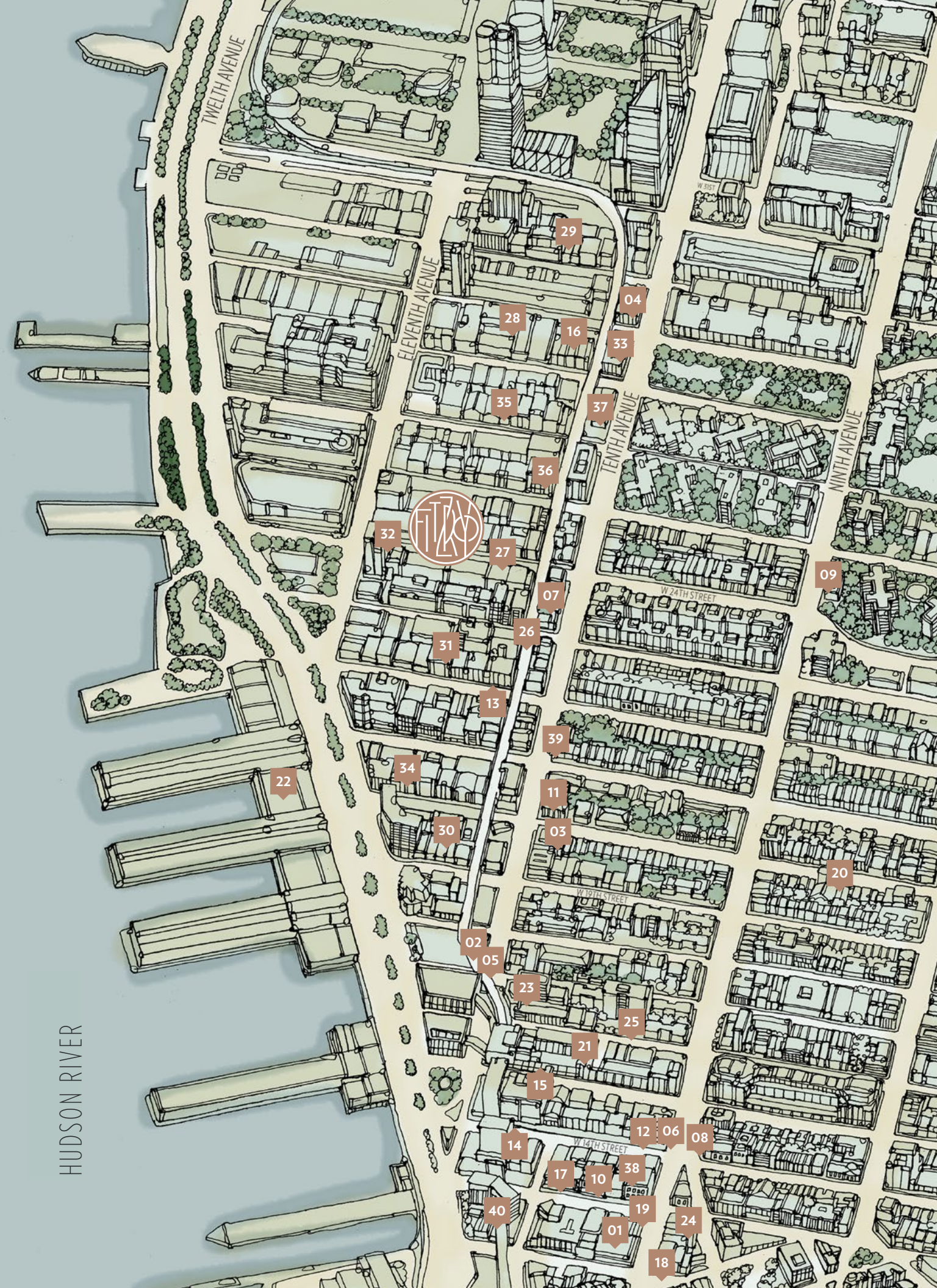

• TEAM •

JDS DEVELOPMENT GROUP • LARGO INVESTMENTS

JDS DEVELOPMENT GROUP

JDS is a real estate development, construction, and acquisition firm based in New York City specializing in raising the bar of luxury residential, hospitality, and mixed-use projects. The team of industry leading professionals has a wide range of experience and unique expertise in the fields of design and construction, hands on project management, results driven sales and marketing, and real estate related financing stemming from experience in development and construction across New York and Miami. Currently, JDS has over seven million square feet of property in various stages of development. Recent projects include the record-setting Walker Tower and Stella Tower, 626 First Avenue, and 111 West 57th Street. Through dedication to superior attention to detail, quality materials, and hard work, JDS projects are crafted to synthesize art, engineering, and ingenuity. The result: quality construction, exceptional living spaces, and carefully considered detailing that harmonize old and new, classic and modern. JDSDEVELOPMENT.COM

LARGO INVESTMENTS

Largo Investments is a private real estate development and investment firm founded by Nissim Ben-Nun and Nicholas Werner. Largo specializes in the acquisition, development, and operation of luxury multifamily and mixed-use real estate in New York City.

Since its founding in 2009, Largo has successfully developed over four hundred thousand square feet of luxury rental apartments, condominiums and retail. Largo is currently developing over one million square feet of mid-rise and high-rise projects throughout Manhattan and Brooklyn.

In addition, Largo provides construction management services for many of its projects through its subsidiary Largo Construction.

LARGOINVESTMENTS.COM

CREDITS

DESIGN KEVIN CANTRELL DESIGN • PHOTOGRAPHY ALPHA SMOOT, NICK ROCHOWSKI
RENDERINGS HAYES DAVIDSON • ILLUSTRATION ABIGAIL DAKER

THE COMPLETE OFFERING TERMS ARE IN AN OFFERING PLAN AVAILABLE FROM SPONSOR. FILE NO. CD15-0088.
SPONSOR: 514 WEST 24TH OWNER LLC, 155 NOBLE STREET, SUITE 2, BROOKLYN, NEW YORK 11222.







All square footages and dimensions are approximate and subject to normal construction variances and tolerances. All computer and/or artist renderings reflect the planned scale and spirit of the Building. All depictions of the condominium property, including without limitation any interior furniture, equipment, decorations, finishes, fixtures, appliances, furnishings, and the maturity of the growth in the landscaping, are for illustrative purposes only. Sponsor makes no representations or warranties except as may be set forth in the Offering Plan.

Where materials, appliances, equipment, fixtures, and/or other construction or design details are specified herein, Sponsor reserves the right to substitute in each instance one of comparable or better quality as recognized by industry standards for performance, efficiency, longevity, and/or classifications, as applicable, in accordance with the terms of the Offering Plan.

Sponsor makes no representation as to the continued existence of any of the named establishments located in the neighborhood. Sponsor makes no representation that future construction in the neighborhood surrounding the Condominium will not result in the obstruction of the views from any windows, gardens, and/or terraces.

